

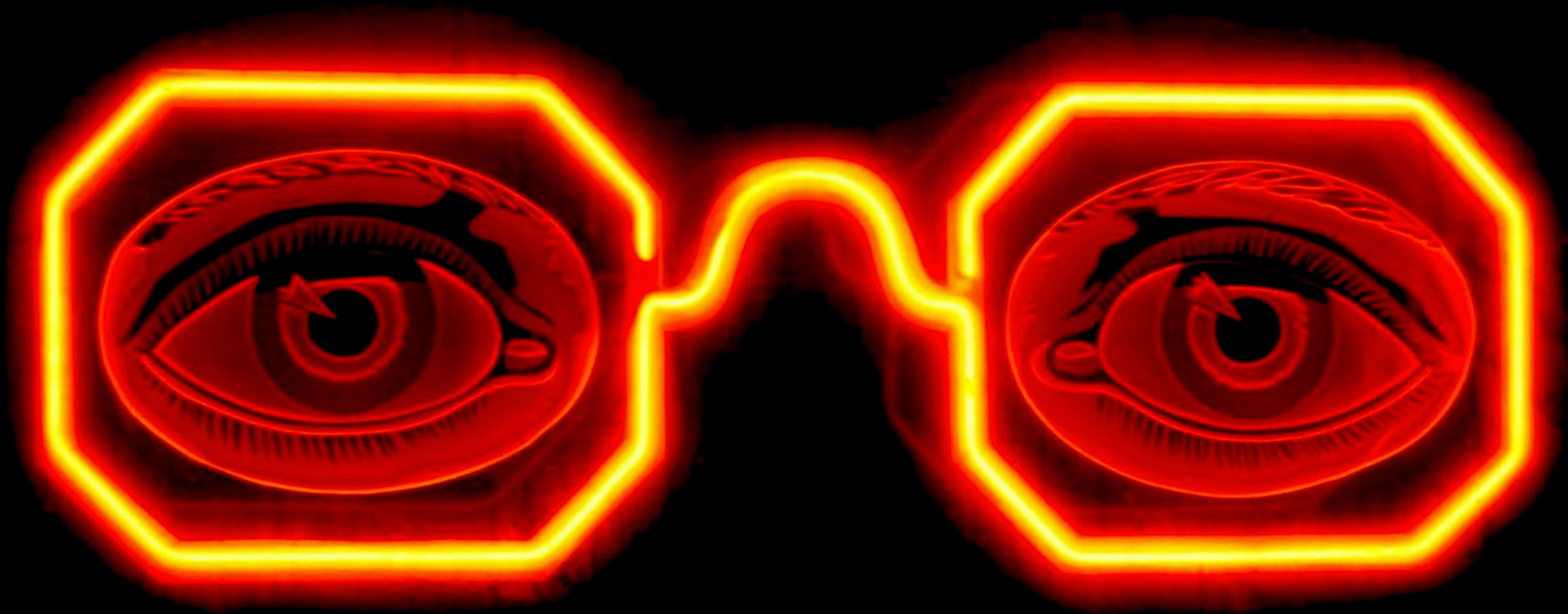

Little Light
STUDIOS

www.littlelightstudios.tv



MESMERIZED

Dictionary

Enter a word, e.g. "pie"



mes·mer·ize

/ˈmezməˌrīz/

verb

past tense: **mesmerized**; past participle: **mesmerized**

hold the attention of (someone) to the exclusion of all else or so as to transfix them.

"she was mesmerized by the blue eyes that stared so intently into her own"

- **ARCHAIC**

hypnotize (someone).

synonyms: **enthral**, hold spellbound, **entrance**, **dazzle**, **bedazzle**, **bewitch**, **charm**, **captivate**, **enchant**, **fascinate**, **transfix**, **grip**, **hypnotize**

"the dancers mesmerized us"



Translations, word origin, and more definitions

Matthew 6:22-24

22 The light of the body is the eye: if therefore thine eye be single, thy whole body shall be full of light.

23 But if thine eye be evil, thy whole body shall be full of darkness. If therefore the light that is in thee be darkness, how great is that darkness!

24 No man can serve two masters: for either he will hate the one, and love the other; or else he will hold to the one, and despise the other. Ye cannot serve God and mammon.





Psalm 101:3

³ I will set no wicked thing before mine eyes: I hate the work of them that turn aside; it shall not cleave to me.

Proverbs 23:7

As a man thinks in his heart, so is he.

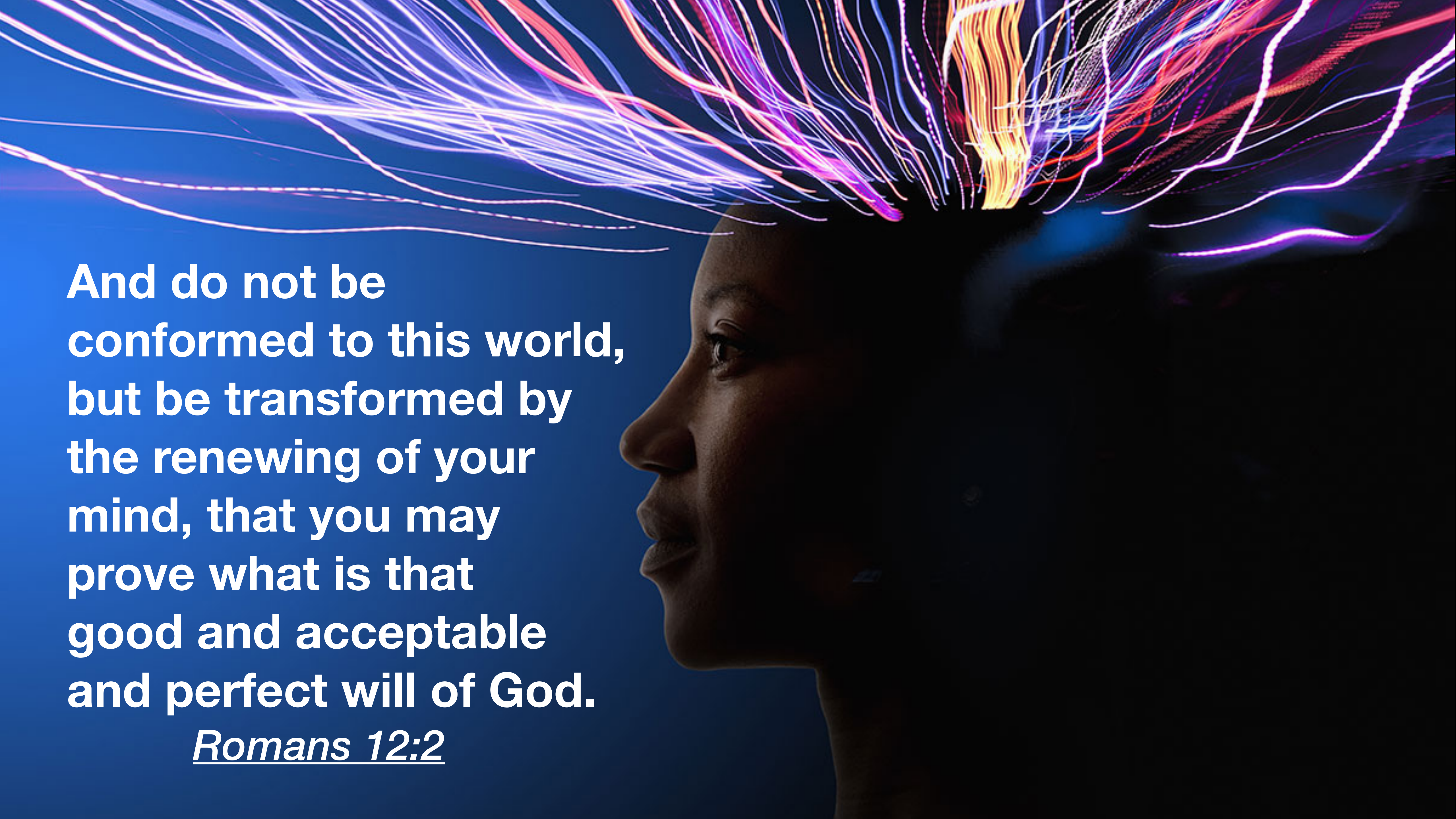

A woman's profile is shown in silhouette against a dark blue background. From the top of her head, a dense array of colorful, glowing fiber optic lines radiates outwards, creating a sense of dynamic energy and thought. The lines are primarily purple, blue, and yellow, with some red and white accents. The overall composition suggests a connection between the human mind and modern technology or digital communication.

**And do not be
conformed to this world,
but be transformed by
the renewing of your
mind, that you may
prove what is that
good and acceptable
and perfect will of God.**

Romans 12:2

**Casting down imaginations,
and every high thing that
exalteth itself against the
knowledge of God, and bringing
into captivity every thought
to the obedience of Christ;
2 Corinthians 10:5**



AMERICAN TIME USE

Did you know that if you work an 8 hour day, you're not the norm? Think your hour or two on Facebook or emailing every day is pretty typical? Think again. The U.S. Department of Labor recently did a survey of how the average American spends their day, the results of which you may find quite surprising.

The Average Employed American's Weekday



Women Ages 35-44 Years Old

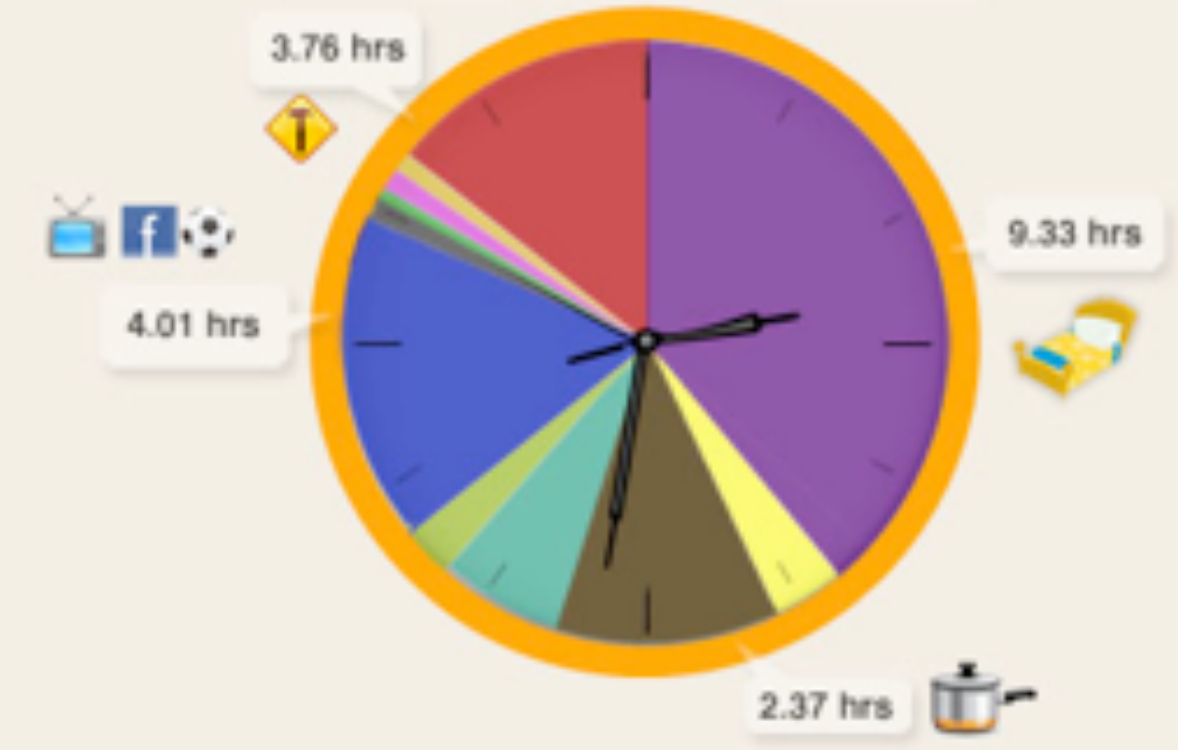

Men Ages 35-44 Years Old

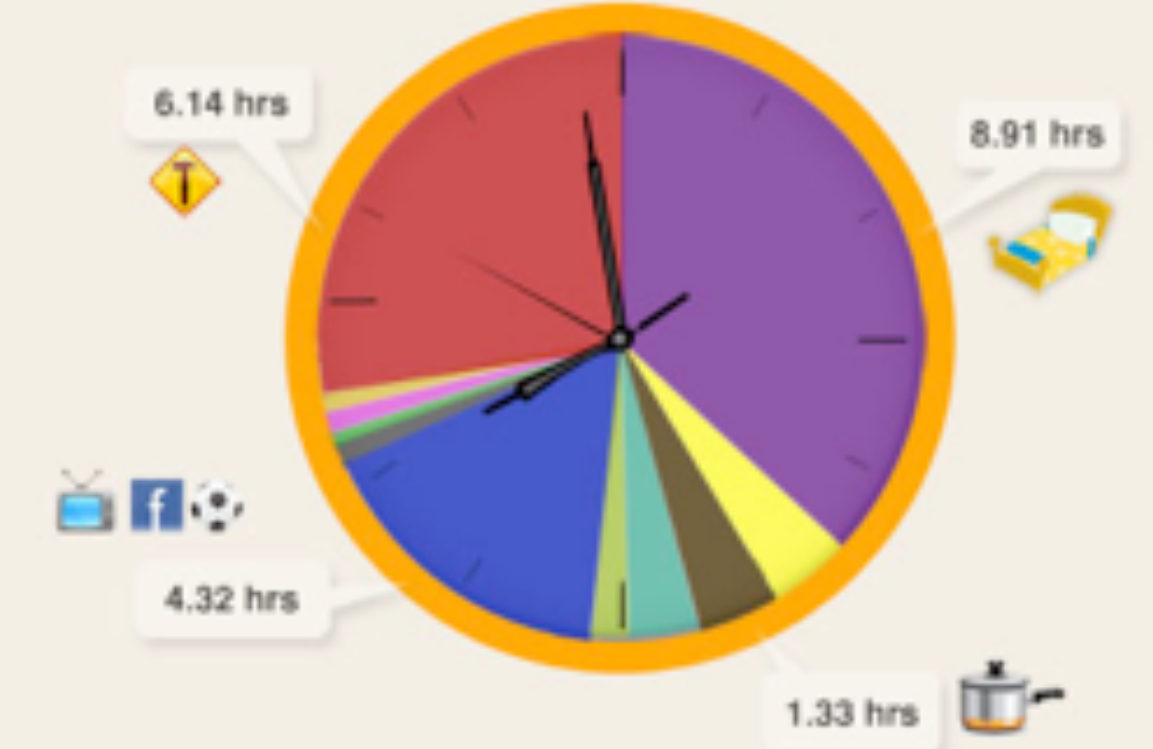

Boys & Girls Ages 15-19 Years Old

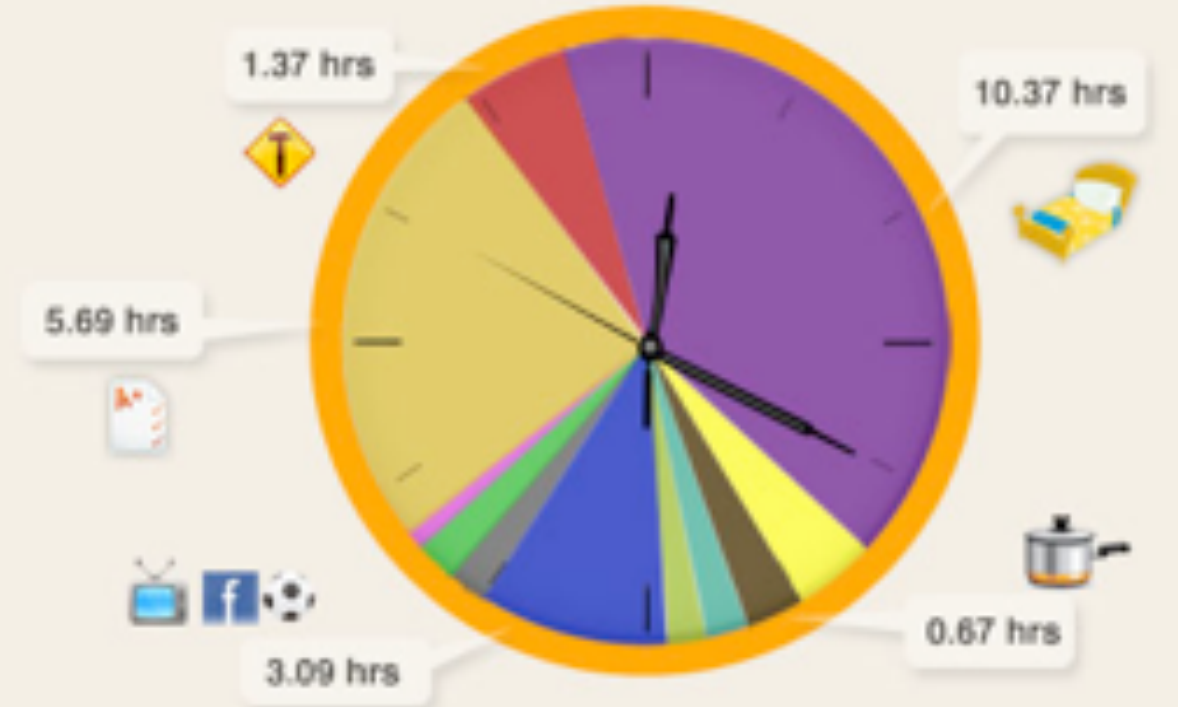

The categories in this infographic refer to an individual's main activity. Other activities done simultaneously are not included. All major activity categories include related travel time. "The Average Employed American" in this graphic has children at home. Statistics are 2008 Annual Averages provided by U.S. Dept. of Labor: <http://www.bls.gov/news.release/atus.nr0.htm>

TIME FLIES: U.S. ADULTS NOW SPEND NEARLY HALF A DAY INTERACTING WITH MEDIA

MEDIA | 07-31-2018

The world has never been more connected, and U.S. audiences have never had as many options to access content as they do these days. In short, consumers in the U.S. seem like they can't get enough content, and the possibilities for marketers to reach them, while fragmented, is an opportunity that is just too good to pass on.

AMERICAN ADULTS SPEND OVER 11 HOURS PER DAY LISTENING TO, WATCHING, READING OR GENERALLY INTERACTING WITH MEDIA

[Tweet](#)

AVERAGE TIME SPENT PER ADULT 18+ PER DAY

Based on Total U.S. Population

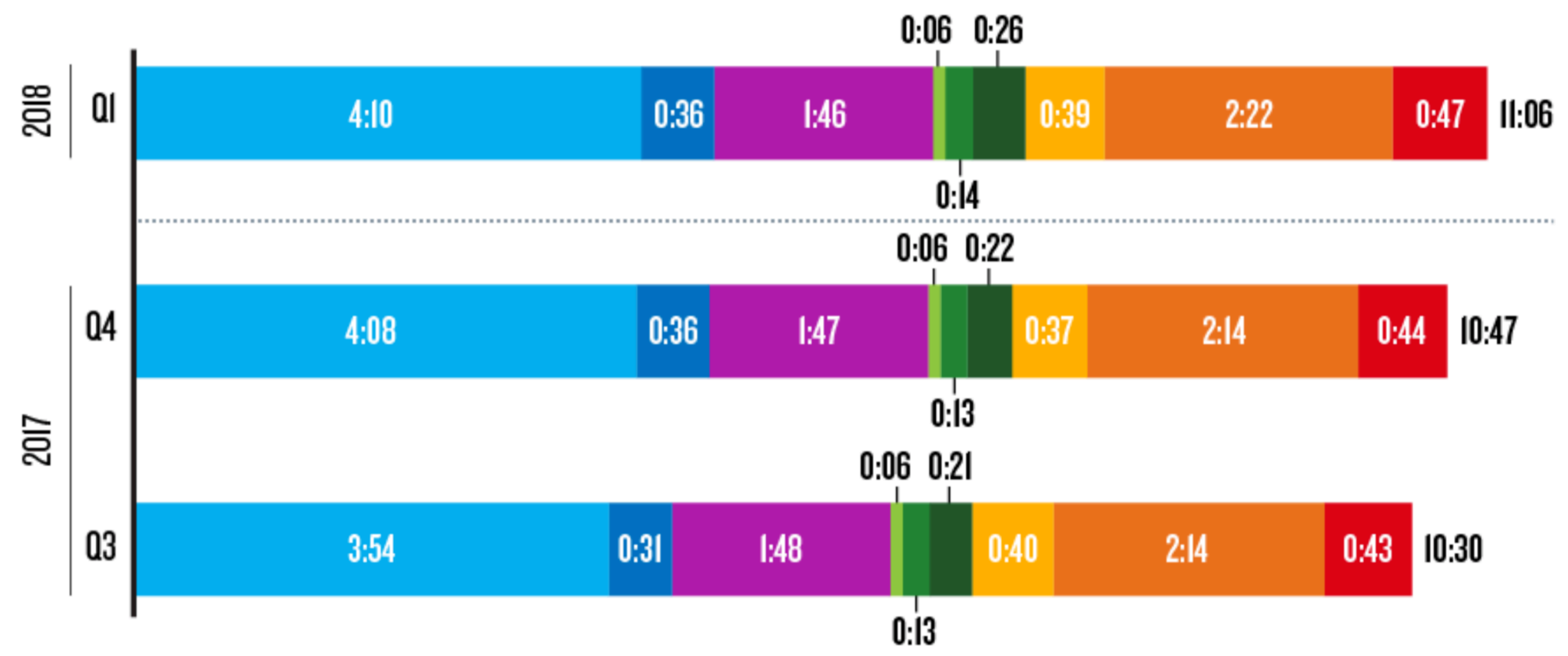

- Live TV
- Time-Shifted TV
- Radio
- DVD/Blu-ray Device
- Game Console
- Internet Connected Device
- Internet on a Computer
- App/Web on a Smartphone
- App/Web on a Tablet

COLE HAUSER BRUCE WILLIS

ACTS OF VIOLENCE

PROTECT WHAT'S YOURS.

IN THEATERS AND ON iTUNES JANUARY 12



Trailer

Play

2:23

**21 Ye have heard that it was said of them of old time,
Thou shalt not kill; and whosoever shall kill shall be in
danger of the judgment:**

**22 But I say unto you, That whosoever is angry with
his brother without a cause shall be in danger of the
judgment:**

Matthew 5:21-22



REBECCA
HALL

DAN
STEVENS

GINA
GERSHON

FRANÇOIS
ARNAUD

MORGAN
SPECTOR

DAVID JOSEPH
CRAIG

AND

JASON
SUDEIKIS

PERMISSION

HOW CAN YOU BE CERTAIN HE IS THE ONE, IF HE IS THE ONLY ONE?



Trailer

Play

1:54



PERMISSION

HOW CAN YOU BE CERTAIN HE IS THE ONE, IF HE IS THE ONLY ONE?



Trailer

Play

1:54

28 But I say unto you, That whosoever looketh on a woman to lust after her hath committed adultery with her already in his heart.

Matthew 5:28

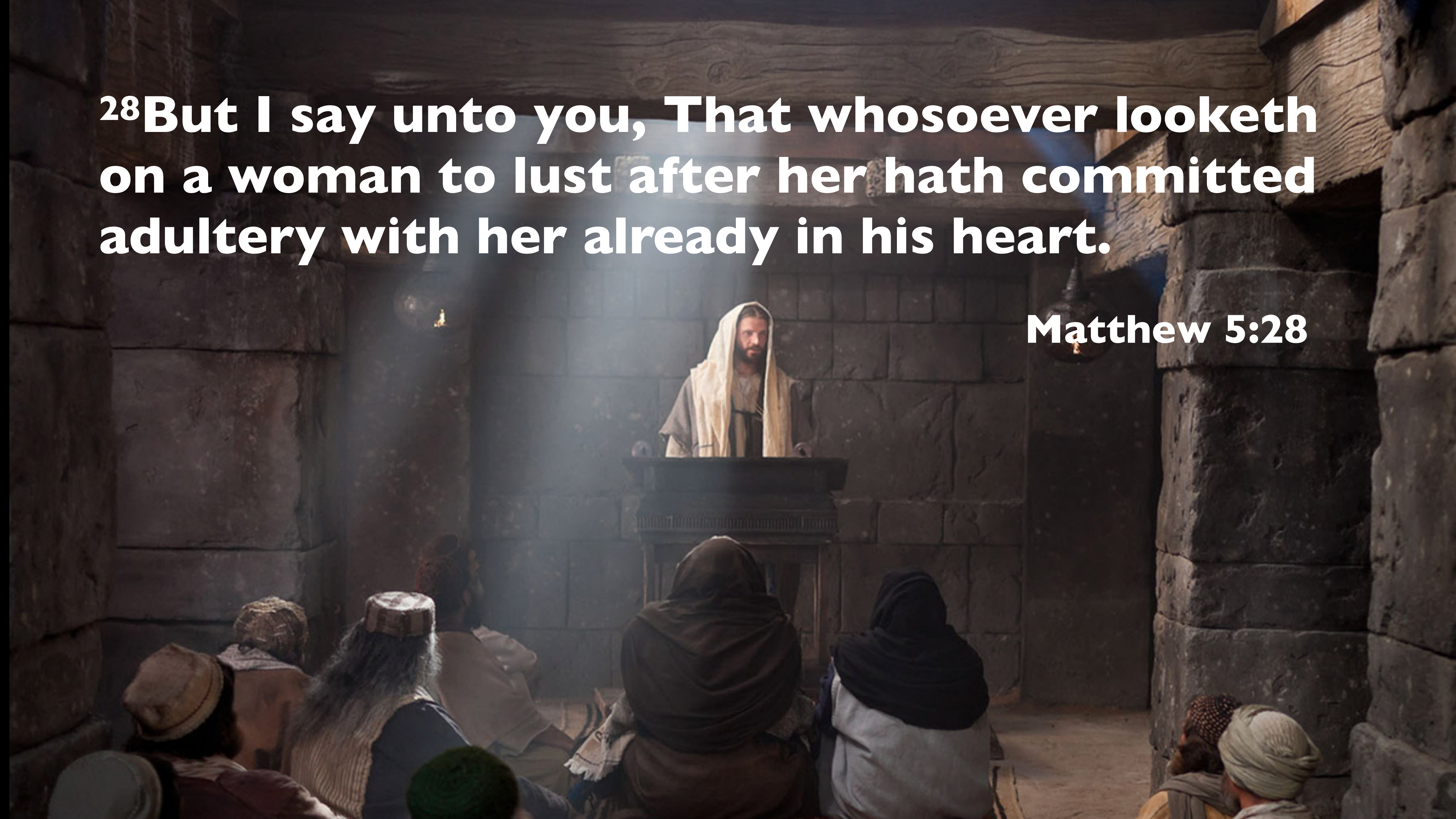

GERARD BUTLER
D'SHEA JACKSON JR
PABLO SCHREIBER
CURTIS "50 CENT"
JACKSON

DEAD OF THE HEAVES

IN THEATERS JANUARY 19



©2017 STX FINANCING, LLC. ALL RIGHTS RESERVED.



Trailer 2

[Play](#) 2:22



Trailer

[Play](#) 2:31

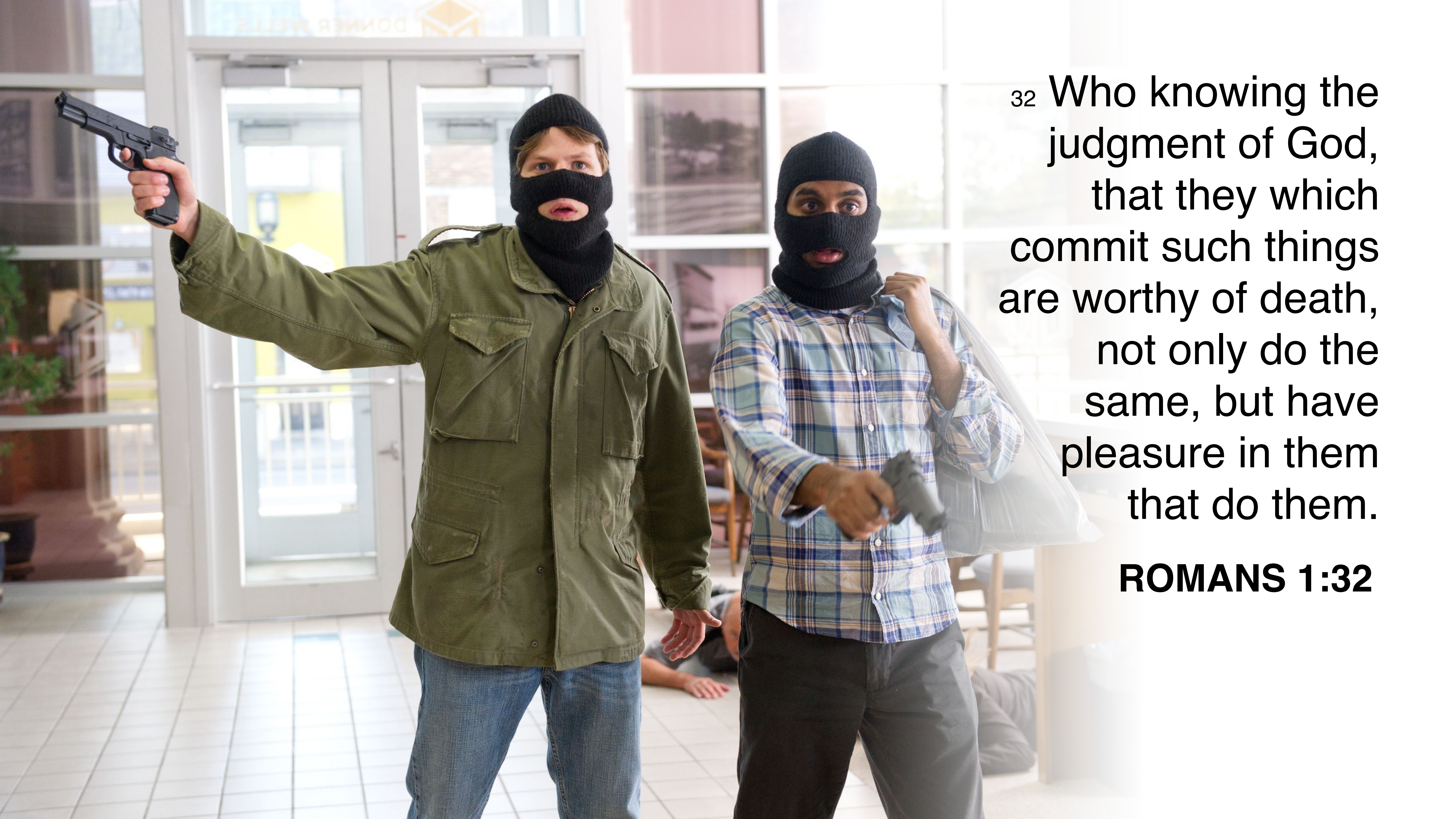

³² Who knowing the judgment of God, that they which commit such things are worthy of death, not only do the same, but have pleasure in them that do them.

ROMANS 1:32



YOUR HEALTH

Does Binge-Watching Make Us Depressed? Good Question

February 4, 2015 · 1:35 PM ET

PONCIE RUTSCH



If 13 episodes in a row with Piper and Crazy Eyes sounds like your dream day, social scientists want to talk with you about your habits.

Paul Schiraldi/Netflix/AP

Netflix and other streaming media services have become the crack of television, making it possible to watch an entire season of shows like *House of Cards* or *Orange Is the New Black* in one go. It seems like harmless fun, but recent headlines suggest that our binge-watching habits could be making us depressed and miserable.

The most recent findings on binge-watching associated people who binge on television with depression, loneliness and an inability to control their behavior.

"Our findings in our research show that those who feel more depressed tend to watch

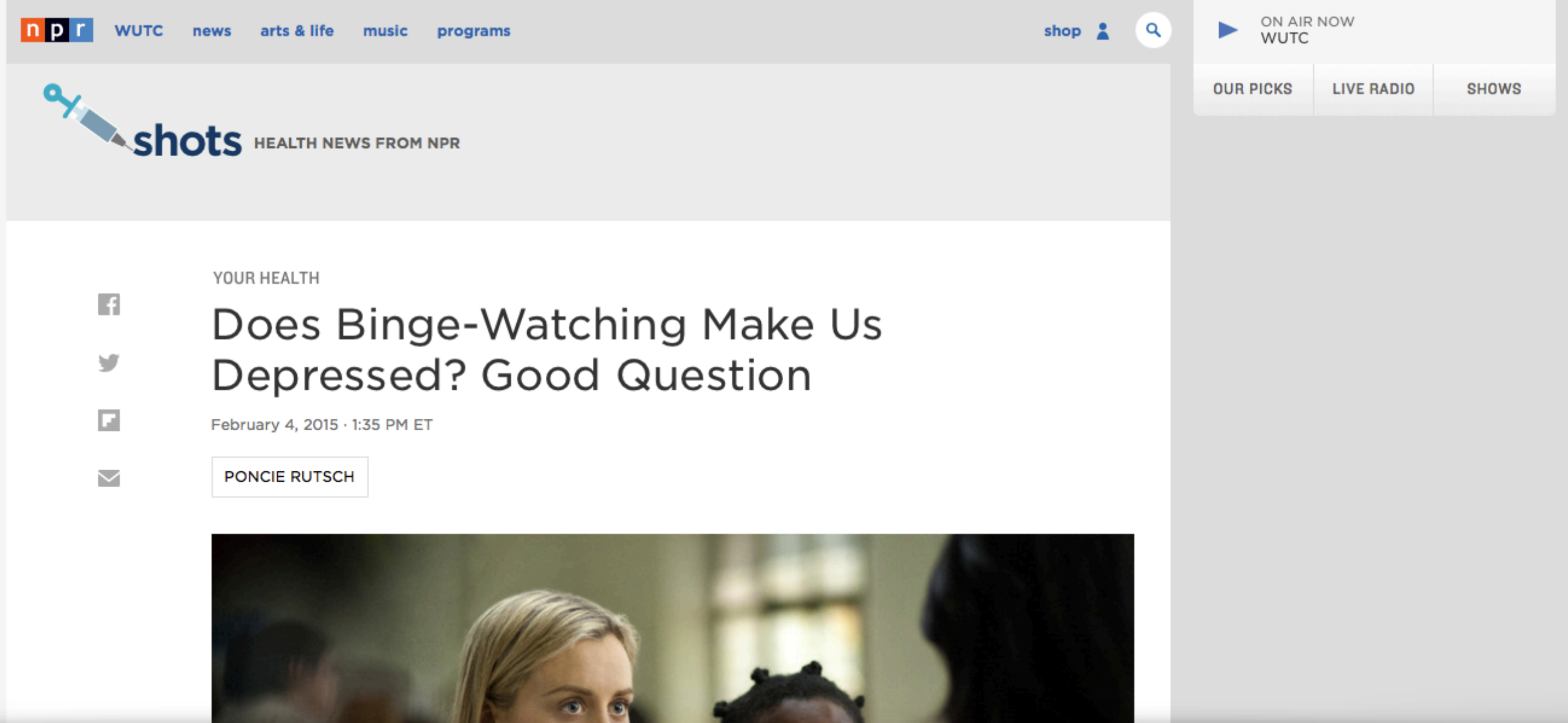

Netflix and other streaming media services have become the crack of television, making it possible to watch an entire season of shows like *House of Cards* or *Orange Is the New Black* in one go. It seems like harmless fun, but recent headlines suggest that our binge-watching habits could be making us depressed and miserable.

The most recent findings on binge-watching associated people who binge on television with depression, loneliness and an inability to control their behavior.

with depression, loneliness and an inability to control their behavior.

"Our findings in our research show that those who feel more depressed tend to watch

nt to power up your kout? Try cursing, ntists say



Megyn Kelly: Some women want to be fat-shamed



Prehistoric 'paradise' discovered in Israel



Women in Sri Lanka are finally allowed to buy alcohol



This bird's feathers are so black they absorb 99.9% of light



A shocking number of Americans never leave home



Why we 'forget' child labor made our jeans, but brag about our...



Woman finds dirty thong in Nordstrom order



LIVING

This is what your Netflix binge is doing to your mental health

By Hannah-Rose Yee

June 15, 2017 | 12:33pm



Brit Marling in Netflix's "The OA." JoJo Whilden/Netflix

ORIGINALLY PUBLISHED BY:



Earlier in the year I formed a really bad habit. I would get home, turn all the lights off, swaddle myself in blankets and slump on my bed to binge-watch four or five episodes of something really, truly gruesome.

First, it was "Midnight Sun," which everyone was talking about and to which I was late to that particular party. Then there was the third season of

"The Fall," which chilled me to my core, and the third season of "Broadchurch," likewise. I finally got around to watching " Fargo." I tangoed briefly with "The OA." Most recently, I spent a furious three nights watching Netflix's brilliant docu-series "The Keepers" from start to finish.

You can see the pattern emerging here, right? Scary shows, viewed in sustained bursts

TRENDING NOW ON NYPOST.COM



232,721

Dashcam shows teen firing at cops before being fatally shot



151,805

Woman returns dead Christmas tree to Costco — in January

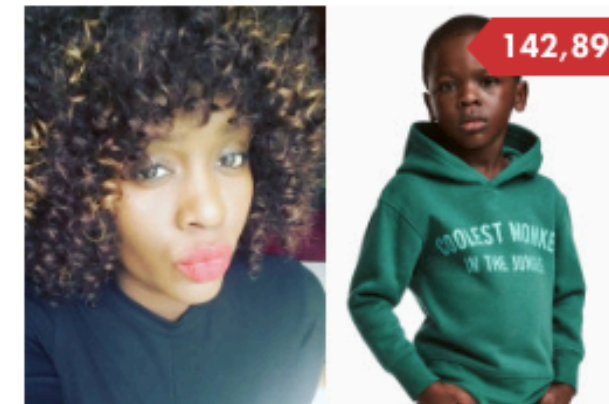

142,895

Mother of boy in H&M's 'coolest monkey' ad says, 'Get over it'

NOW ON Page Six

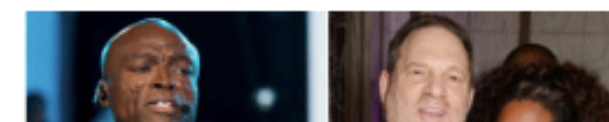

WELLNESS

What Happens to Your Brain When You Binge-Watch a TV Series

Is watching the entire second season of "Stranger Things" on your weekend to-do list? Here's what you need to know.

by Danielle Page / Nov.04.2017 / 3:51 PM ET



— A Netflix survey found that 73 percent of participants reported positive feelings associated with binge-watching. harpazo_hope / Getty Images

You sit yourself down in front of the TV after a long day at work, and decide to start watching that new show everyone's been talking about. Cut to midnight and you've crushed half a season – and find yourself tempted to stay up to watch just *one more* episode, even though you know you'll be paying for it at work the next **morning**.

It happens to the best of us. Thanks to streaming platforms like Netflix and Hulu, we're granted access to several hundred show

Get the Better
newsletter.

SUBSCRIBE

A photograph of a church with a tall bell tower, situated in a desert landscape. The scene is overlaid with a large, semi-transparent rainbow graphic that spans the width of the image. The church is the central focus, with its architecture clearly visible against the sky. The foreground is a sandy, arid plain. The overall mood is contemplative and spiritual.

LAODICEA

LUKEWARM CHRISTIANITY

A church with a tall bell tower stands in a desert landscape. A rainbow is visible in the sky, with its colors transitioning from red on the left to blue on the right. The church is in the center, with a few trees to its right. The ground is sandy and sparsely vegetated.

LAODICEA

LUKEWARM CHRISTIANITY

15 I know thy works, that thou art neither cold nor hot: I would thou wert cold or hot.

16 So then because thou art lukewarm, and neither cold nor hot, I will spue thee out of my mouth.

17 Because thou sayest, I am rich, and increased with goods, and have need of nothing; and knowest not that thou art wretched, and miserable, and poor, and blind, and naked:

wretched | 'reCHəd |

adjective (wretcheder, wretchedest)

1. (of a person) in a very unhappy or unfortunate state:

adjective:

miserable, unhappy, sad, heartbroken, grief-stricken, sorrowful, sorry for oneself, distressed, desolate, devastated, despairing, disconsolate, downcast, dejected, crestfallen, cheerless, depressed, melancholy, morose, gloomy, mournful, doleful, dismal, forlorn, woebegone; *informal* blue; *literary* dolorous. ANTONYMS cheerful.



Music News: Antonique Smith Kick-starts Her Music Career



Music News: Meshell Ndegeocello on Nina Simone, Frank Ocean and



Musi MGK Laced

◀ Previous Cam'ron to Release New Solo Album in April

Music

Didd

Nicki Minaj and Lil Wayne Receive "Teacher of the Year" Awards

A Florida education company credited the duo's swagger for getting students' attention.

By Dorkys Ramos

Posted: 12/18/2011 06:41 PM EST

Filed Under [Lil Wayne](#), [Music News](#), [Education](#), [Nicki Minaj](#), [Hip Hop](#)





This is sure to tilt some heads, but a Florida education company has announced that rappers [Nicki Minaj](#) and [Lil Wayne](#) are to receive their first annual "Teacher of the Year" awards. The South Florida-based [Better Education Place](#) named the two as the Best Male and Best Female Teacher after judging them on several categories and deeming them more influential than the teachers who actually commit themselves to children's education.

"Apparently students are drawn in by the 'swagger,'" says [Melvin El](#), president of Better Education Place. "If you are a teacher today and you don't have any swagger, you are going to struggle to get your students' attention. It turns out a teacher can learn a lot from Lil Wayne and Nicki Minaj."

Because the company encourages using hip hop to make education fun, they've deemed rappers worthy of receiving the awards.



This is sure to tilt some heads, but a Florida education company has announced that rappers **Nicki Minaj** and **Lil Wayne** are to receive their first annual "Teacher of the Year" awards. The South Florida-based **Better Education Place** named the two as the Best Male and Best Female Teacher after judging them on several categories and deeming them more influential than the teachers who actually commit themselves to children's education.

"Apparently students are drawn in by the 'swagger,'" says **Melvin El**, president of Better Education Place. "If you are a teacher today and you don't have any swagger, you are going to struggle to get your students' attention. It turns out a teacher can learn a lot from Lil Wayne and Nicki Minaj."

Because the company encourages using hip hop to make education fun, they've deemed rappers worthy of receiving the awards.

TIME

THE POWER OF TAYLOR SWIFT

BY JACK DICKEY



ters. She hugged Harvey Weinstein, who got her a role in *The Giver*, like an old friend.

By night, the waiters had switched to pizza, the crowd had turned civilian, and Swift had replaced her sleek all-black ensemble with a navy dress bearing white polka dots and a gold necklace that read T.S. 1989. When she entered, the brigade of fans, pre-vaillingly female and in their late teens and early 20s, queued behind Caylee like supplicants in want of benediction.

Swift is happy to minister to them. "They're discovering the music that tells them how they are going to live their lives and how they should feel and how it's acceptable to feel," Swift says. "I think that that's kind of exciting." To her fans she has recently started speaking out on two connected matters of importance to her: the music business and feminism.

On Nov. 3, almost all Swift's music vanished from Spotify, the online streaming service that claims over 50 million active users, more than 10 million of whom pay for an ad-free and mobile-ready version. Swift's departure came as a surprise to plenty of those users.



'OUR SONG'

Taylor Swift, 2006

A catchy country jam about a fun, free high school romance in need of an anthem

Celebrity Worship: Good for Your Health?

By Alice Park | Monday, Sept. 15, 2008

Like 24

Tweet

G+

in Share 3

Read Later

Who among us hasn't fallen victim to a little celebrity worship? Whether the object of our affections are movie stars, athletes, poets or politicians (just look at how many Americans are getting a buzz off Sarah Palin and Barack Obama), we're hungry for information about them. We want to know what they're saying, what they're wearing, where they're going and whom they're with. Indeed, billion-dollar industries revolve around our indefatigable obsession with celebrities. And now new scientific research has found that celebri-crushes are not only common but maybe even healthy: a study published Sept. 10 suggests that the act of celebrity worship may be a boon to some people's self-esteem.

Shira Gabriel, a psychologist at the University at Buffalo, conducted a series of three studies on celebrity worship, focusing specifically on how admiration from afar may affect the admirer's self-esteem. "It was seven or eight years ago during the Michael Jackson trial," she says, "and I was fascinated by the people who were obsessed with him, who flew to the trial and made banners. I thought, What would bring somebody to do



Brooks Kraft / Corbis for TIME

Alaska governor Sarah Palin greets the crowd after attending a rally for Republican presidential candidate John McCain in Lee's Summit, Mo.

RELATED

Will Hollywood Cast Lindsay Adrift?

Celebrity Worship: Good for Your Health?

By Alice Park | Monday, Sept. 15, 2008

Like 24

Tweet

G+

in Share 3

Read Later

Who among us hasn't fallen victim to a little celebrity worship? Whether the object of our affections are movie stars, athletes, poets or politicians (just look at how many Americans are getting a buzz off Sarah Palin and Barack Obama), we're hungry for information about them. We want to know what they're saying, what they're wearing, where they're going and whom they're with. Indeed, billion-dollar industries revolve around our indefatigable



second test — almost as high as those who started out with the highest self-esteem scores — after they wrote about their best-loved celebrities. "Because people form bonds in their mind with their favorite celebrities, they are able to assimilate the celebrity's characteristics in themselves and feel better about themselves when they think about that celebrity," says Gabriel. "And that is something these individuals can't do in real relationships because their fear of rejection keeps them from getting close to people."

Shira Gabriel, a psychologist at the University at Buffalo, conducted a series of three studies on celebrity worship, focusing specifically on how admiration from afar may affect the admirer's self-esteem. "It was seven or eight years ago during the Michael Jackson trial," she says, "and I was fascinated by the people who were obsessed with him, who flew to the trial and made banners. I thought, What would bring somebody to do

RELATED

Will Hollywood Cast Lindsay Adrift?



THE EARLY SHOW
Jennifer Lopez,
Steven Tyler New
"Idol" Judges?

4 of 9



VIDEO
World's Most
Expensive Hot Dog

5 of 9



STRANGE
Zedonk! (It's A
Donkey-Zebra
Hybrid Baby)

6 of 9

[Home](#) > [Health](#) > [WebMD](#)

March 3, 2006

A New Age Of Celebrity Worship

Experts Dissect The Good, The Bad, And The Ugly Of Being A Fan

By Christine Lagorio

Font size [Print](#) [E-mail](#) [Share](#) Page 1 of 3

Like this Story? Share it:

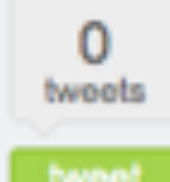

Love Brad and Angelina? Is it a harmless crush or a celebrity worship that could be dangerous to your health? (AP Photo/Twentieth Century Fox)



PHOTO ESSAY
Celebrity Circuit

Jessica's stadium cheer, Celine's

(WebMD) Brad and Angelina, Tom and Katie, Nick and Jessica - it seems people can't get enough of hearing about the gritty details of celebrities' lives.

It's called being "star struck," and it's a phenomenon that is not only bigger than life - it's bigger than ever.

"You have a confluence of forces coming together in technology and the media to make it happen and it's worldwide and it's multiplying like lice," says Stuart Fischhoff, Ph.D., spokesman for the American Psychological Association and professor emeritus of media psychology at the California State University at Los Angeles.

Indeed, from the international mania of the New York Post's Page Six, to increasing circulation of celebrity-driven publications like People, US, OK, and In Style, to the cult star status of gossip reporters like Entertainment Tonight's Mary Hart and the New York Daily News' Rush & Malloy, there is no question that all-things-celebrity have captured - and are keeping - our attention like never before.

But what drives our endless fascination with celebrity worship? And more important, can its enticing seduction ever be harmful to our health?

The answer, it seems, depends a lot on who is doing the worshipping - and the reasons why.

"Like most things there's a dimensional approach here; there are some people who are fascinated by celebrities lives, but also involved in meaningful activities and relationships in their own lives, and for those people star watching is usually a harmless diversion."

Ad info ▾

cnet What Can You Do with 4G?

Visit the Sprint 4G Showcase on CNET

[Learn more](#)

Sponsored by

Sprint



MOST POPULAR

VIEWED

1. [Shirley Sherrod Says She'll Sue Andrew Breitbart](#)
 2. [Teen Charged in Teacher Slaying, Rape at Juvenile Detention Center](#)
 3. [Obama on The View: Racial Labels Don't Matter](#)
 4. [Charlie Rangel: List of Charges](#)
 5. [Chelsea Clinton's Wedding Day Details](#)
- [More Popular Stories and Video](#)

DISCUSSED

1. [Judge Hands Victory to AZ Immigration Law Foes](#)
(1339 recent comments)



THE EARLY SHOW
Jennifer Lopez,
Steven Tyler New
"Idol" Judges?

4 of 9



VIDEO
World's Most
Expensive Hot Dog

5 of 9



STRANGE
Zedonk! (It's A
Donkey-Zebra
Hybrid Baby)

6 of 9

Home > Health > WebMD

March 3, 2006

A New Age Of Celebrity Worship

Experts Dissect The Good, The Bad, And The Ugly Of Being A Fan

By Christine Lagorio

Font size Print E-mail Share Page 1 of 3

Like this Story? Share it:

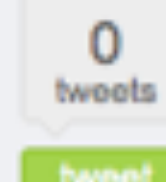

(WebMD) Brad and Angelina, Tom and Katie, Nick and Jessica - it seems people can't get enough of hearing about the gritty details of celebrities' lives.

It's called being "star struck," and it's a phenomenon that is not only bigger than life - it's bigger than ever.

"You have a confluence of forces coming together in technology and the media to make it happen and it's worldwide and it's multiplying like lice," says Stuart Fischhoff, Ph.D., spokesman for the American Psychological Association and professor emeritus of media psychology at the California State University at Los Angeles.

Indeed, from the international mania of the New York Post's Page Six, to increasing circulation of celebrity-driven publications like People, US, OK, and In Style, to the cult star status of gossip reporters like Entertainment Tonight's Mary Hart and the New York

Ad info

cnet What Can You Do with 4G?

Visit the Sprint 4G Showcase on CNET

Learn more

Sponsored by

Sprint



- MOST POPULAR**
- VIEWED
1. Shirley Sherrod Says She'll Sue Andrew Breitbart
 2. Teen Charged In Teacher Slaying, Rape at

Fischhoff, who has academically studied the cult of celebrity, says the very need to find an idol and follow him is programmed into our DNA.

your health? (AP Photo/Twentieth Century Fox)



PHOTO ESSAY
Celebrity Circuit
Jessica's stadium cheer, Celine's

worshipping - and the reasons why.

"Like most things there's a dimensional approach here; there are some people who are fascinated by celebrities lives, but also involved in meaningful activities and relationships in their own lives, and for those people star watching is usually a harmless diversion."

DISCUSSED

1. Judge Hands Victory to AZ Immigration Law Foes (1339 recent comments)

'Anchorman 2': Durango Sales Up Nearly 40% Thanks to Ron Burgundy Ads

MOVIES | By Brent Lang on December 16, 2013 @ 4:13 pm [Follow @brentalang](#)

[f](#) 72 [t](#) 56 [in](#) 11 [g+](#) 0 [st](#) 0 [s](#) 1 [s](#) 1760 [Email](#) [Print](#)



"The engagement with this campaign has been huge and the mere fact that it has found its way into pop culture is the biggest indication of success," Olivier Francois, Chrysler Group chief marketing officer, told **TheWrap**.

Also read: [How Will Ferrell's Ron Burgundy Became Dodge's Best Car Salesman Ever](#)

"We approached the campaign through the lens of someone who could tell the story of the Dodge Durango's horsepower, fuel efficiency and technology in an entertaining way," he added. "We thought, who better than Ron Burgundy?"

That has led to more than a half-billion media impressions, the company told TheWrap.

THE LATEST



Chuck Lorre Achieves Rare
Dylan Farrow Responds to Backlash - and Brother's 'Evil' Betrayal - Over Woody Allen Sex Abuse Allegations



'Anchorman 2': Durango Sales Up Nearly 40% Thanks to Ron Burgundy Ads

MOVIES | By Brent Lang on December 16, 2013 @ 4:13 pm

Follow @brentalang

f 72 t 56 in 11 g+1 0 r 0 s 1 1760 Email Print



THE LATEST



Catherine Zeta Jones for T-Mobile



Paid \$20 Million



 **FREE** YOUR
SWING

**Tiger Woods for Nike
Paid \$100 Million**





**David Beckham
for Adidas**

adidas[®]

Paid \$160 Million

The greatest want of the world is the want of men—men who will not be bought or sold, men who in their inmost souls are true and honest, men who do not fear to call sin by its right name, men whose conscience is as true to duty as the needle to the pole, men who will stand for the right though the heavens fall.

-Education p.57



..... A61N 2/00; A61B 5/04;
A61M 21/00
..... 600/27; 600/545
..... 600/9-27, 545;
419; 324/318; 378/901; 434/236

References Cited

U.S. PATENT DOCUMENTS

71 Diaz 313/419
89 Ross et al. 600/545
92 Brennan 600/26
94 Mrklas et al. 434/236
95 Yassa et al. 378/901
95 Ziarati 324/318
95 Litovitz 600/9
98 Loos 607/2
98 Loos 607/100
99 Loos 607/2
99 Loos 600/9
00 Loos 600/28
00 Loos 607/2
00 Loos 607/100
00 Loos 607/2

Assistant Examiner—Nikita R Veniaminov

(57)

ABSTRACT

Physiological effects have been observed in a human subject in response to stimulation of the skin with weak electromagnetic fields that are pulsed with certain frequencies near $\frac{1}{2}$ Hz or 2.4 Hz, such as to excite a sensory resonance. Many computer monitors and TV tubes, when displaying pulsed images, emit pulsed electromagnetic fields of sufficient amplitudes to cause such excitation. It is therefore possible to manipulate the nervous system of a subject by pulsing images displayed on a nearby computer monitor or TV set. For the latter, the image pulsing may be imbedded in the program material, or it may be overlaid by modulating a video stream, either as an RF signal or as a video signal. The image displayed on a computer monitor may be pulsed effectively by a simple computer program. For certain monitors, pulsed electromagnetic fields capable of exciting sensory resonances in nearby subjects may be generated even as the displayed images are pulsed with subliminal intensity.

14 Claims, 9 Drawing Sheets

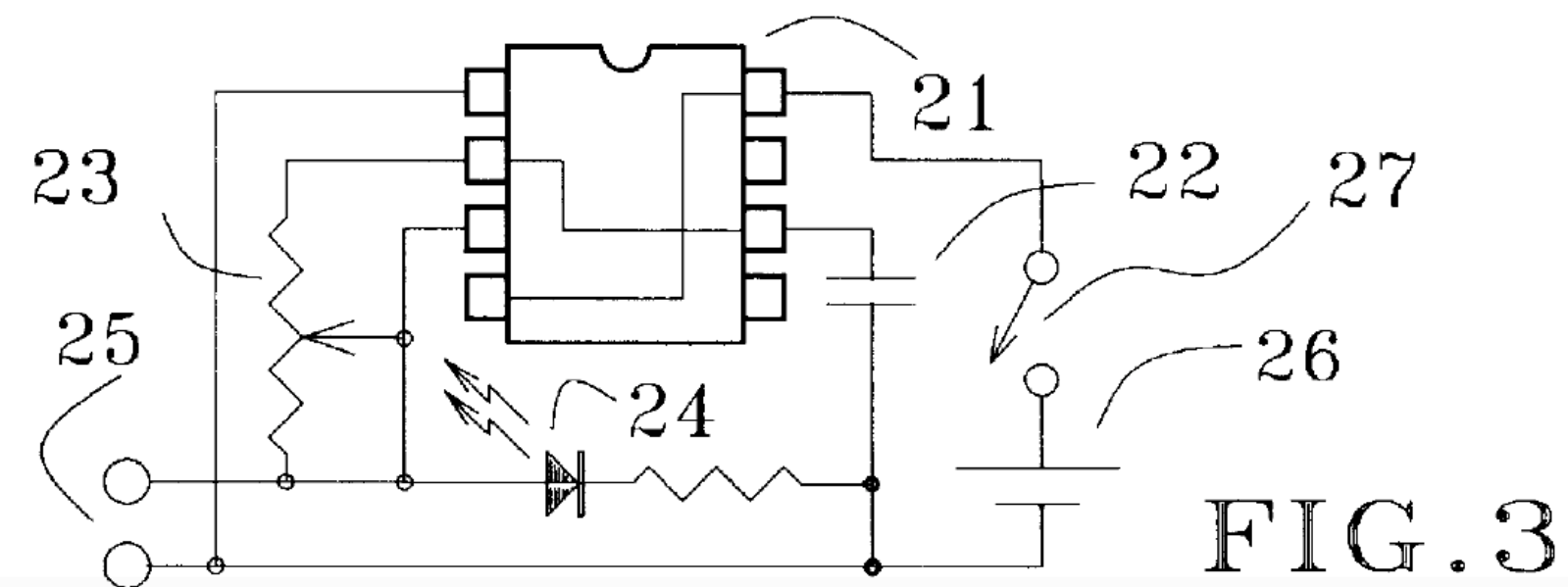
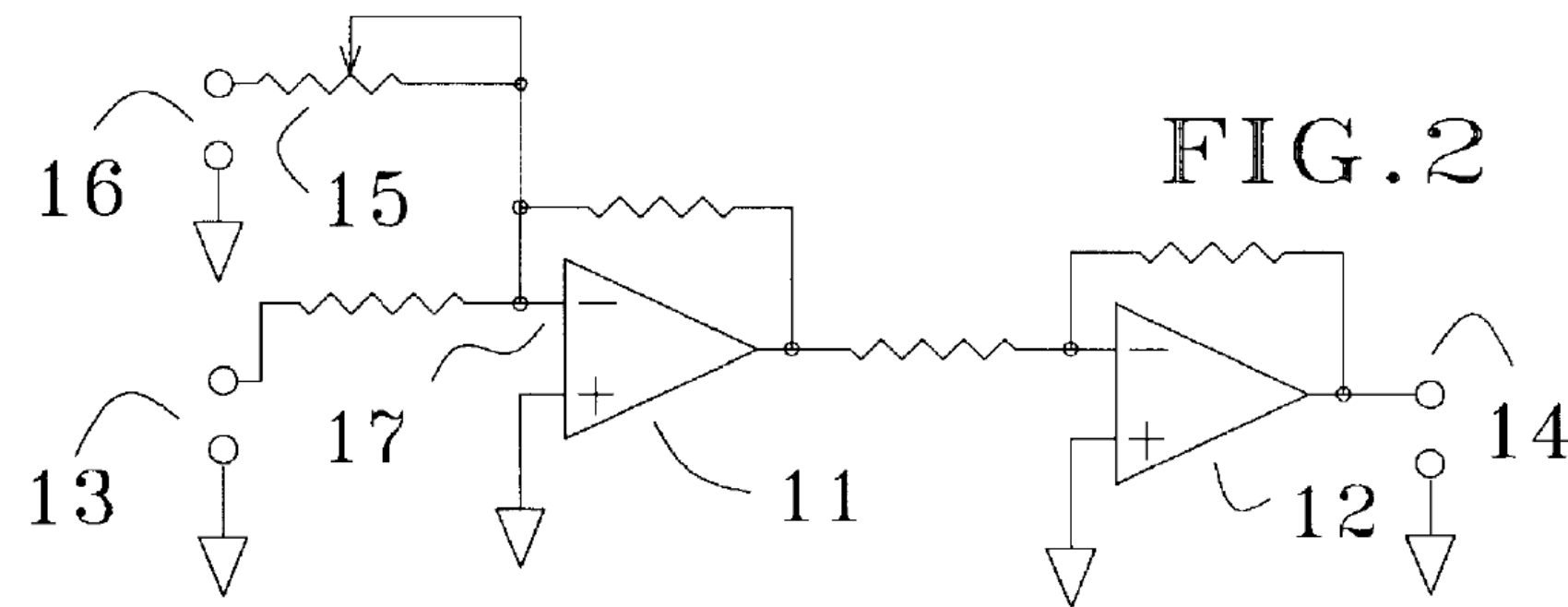
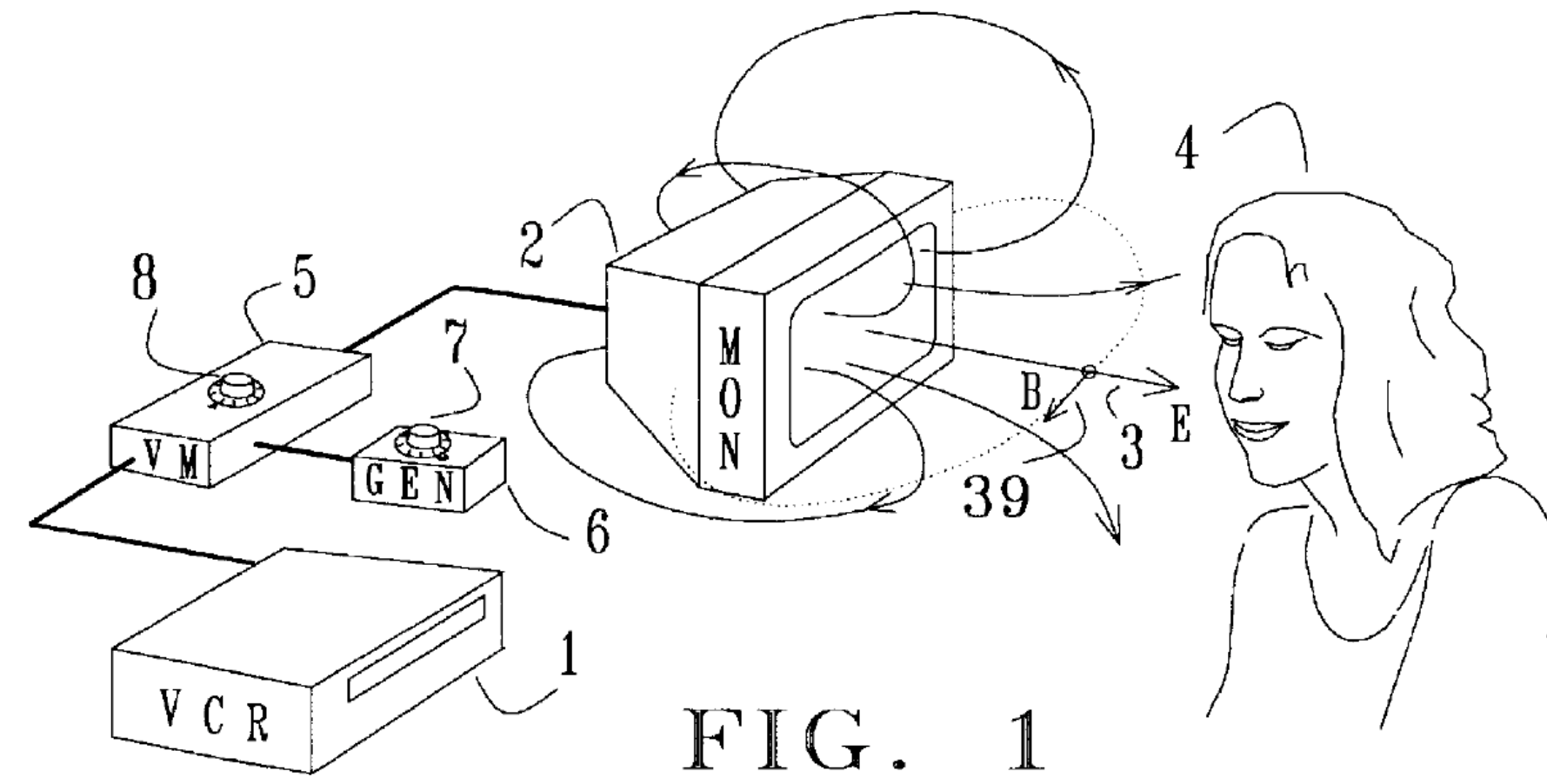

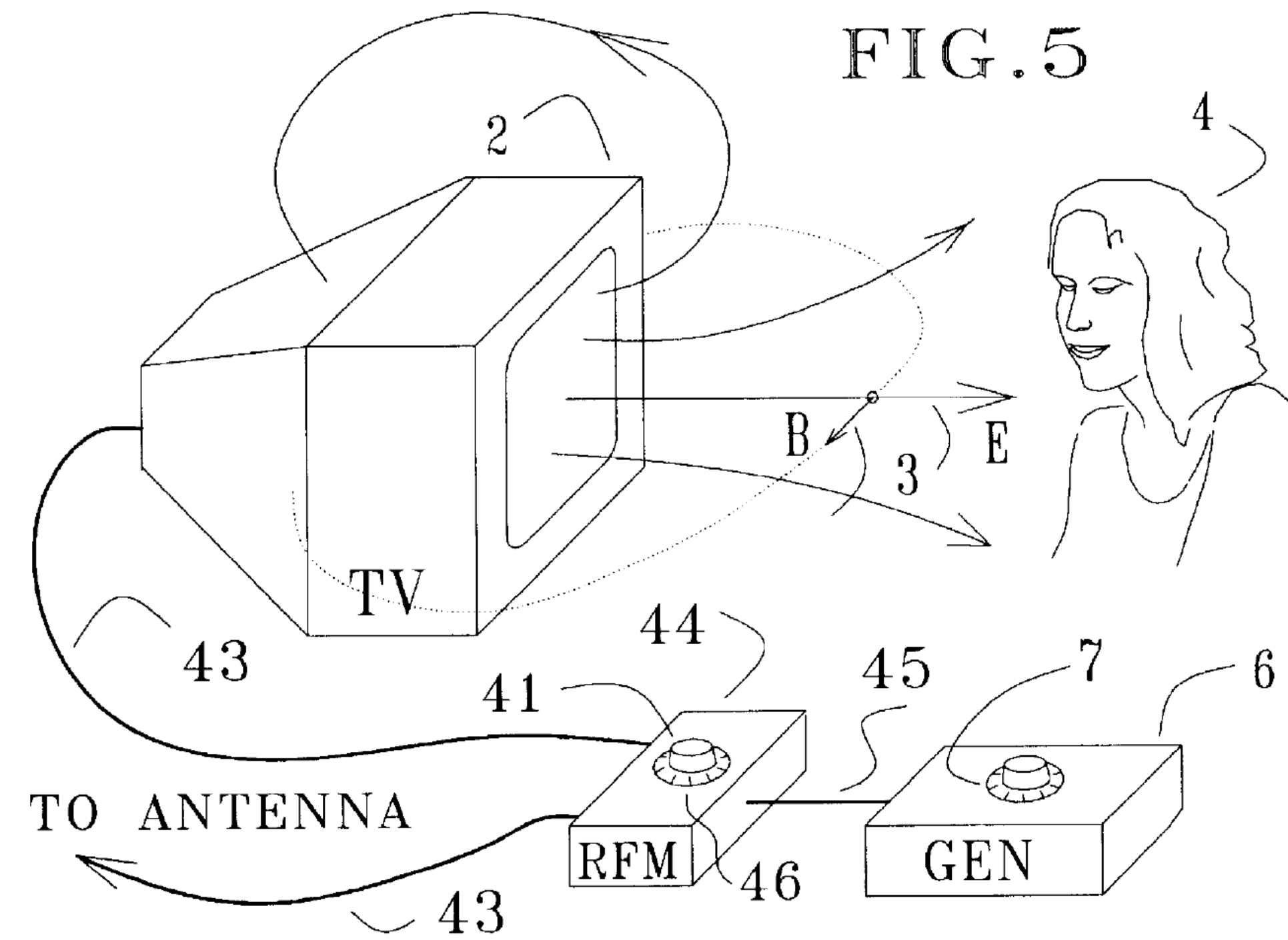
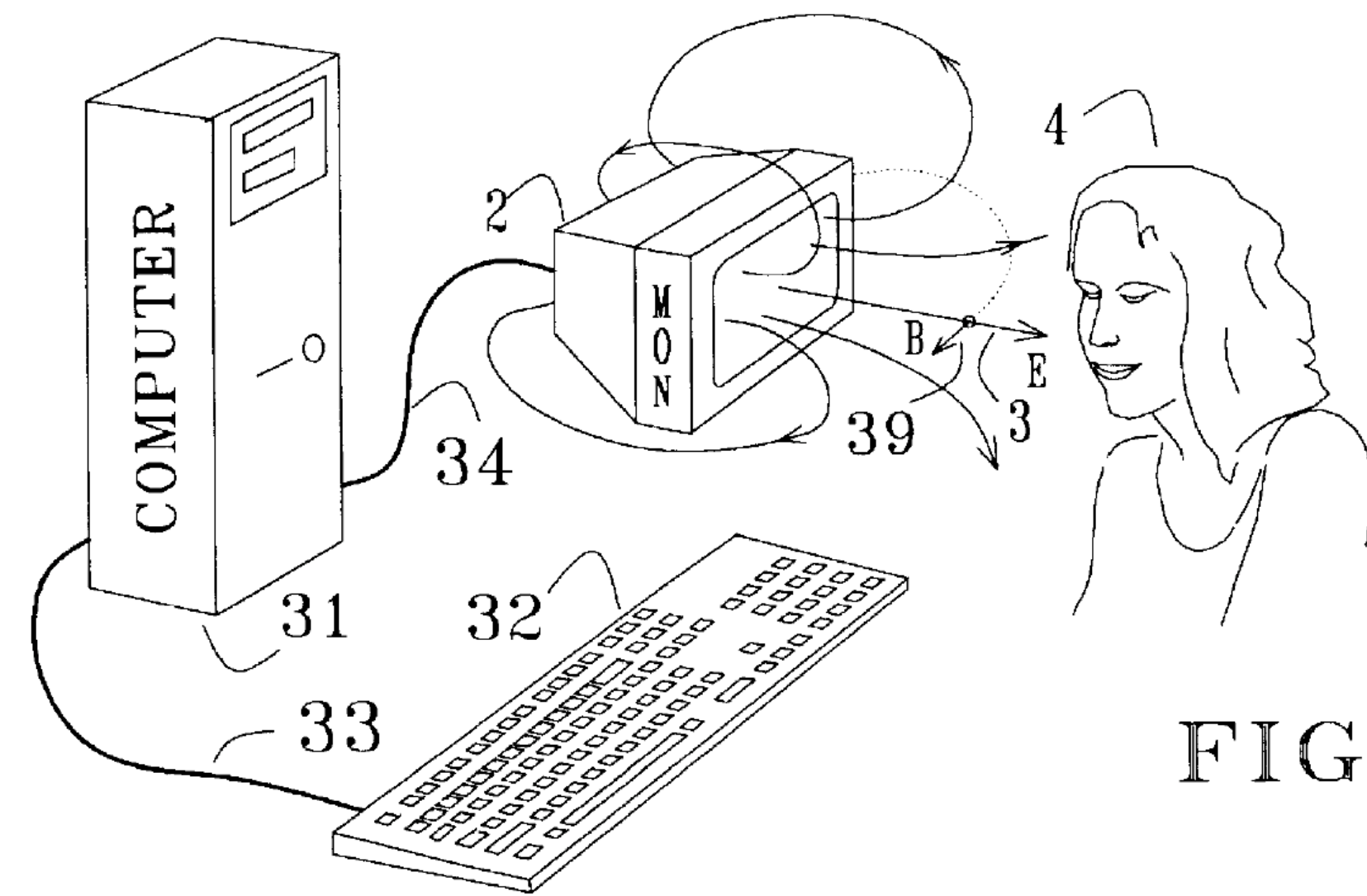

perturbations spread by diffusion to circuits. This effect, called "chemical" is so strong that ptosis is lost altogether if the frequency is kept constant in the initial stimulation. Since the stimulation then falls below the resonance, the resonance decreases in amplitude and eventually diminishes. This causes the ptosis to shift back up, so that the stimulation can develop again. As a result, at frequencies in a certain range, the ptosis can be maintained with a frequency of several minutes. This is described in the '302 patent.

Frequencies at which specific physiological responses depend somewhat on the autonomic nervous system and probably on the endocrine state as well.

Fields that are pulsed with a sensory frequency can induce the same physiological responses as static fields. Unlike the latter however, they penetrate biological tissue with nearly equal ease. Eddy currents in the tissue drive charges to the skin, where the charge distributions are smeared in much the same way as in electrostatic induction, so that the same physiological

stream may be modulated such as to overlay the pulsing. In the first case, a live TV broadcast can be arranged to have the feature imbedded simply by slightly pulsing the illumination of the scene that is being broadcast. This method can of course also be used in making movies and recording video tapes and DVDs.

Video tapes can be edited such as to overlay the pulsing by means of modulating hardware. A simple modulator is discussed wherein the luminance signal of composite video is pulsed without affecting the chroma signal. The same effect may be introduced at the consumer end, by modulating the video stream that is produced by the video source. A DVD can be edited through software, by introducing pulse-like variations in the digital RGB signals. Image intensity pulses can be overlaid onto the analog component video output of a DVD player by modulating the luminance signal component. Before entering the TV set, a television signal can be modulated such as to cause pulsing of the image intensity by means of a variable delay line that is connected to a pulse generator.

Certain monitors can emit electromagnetic field pulses that excite a sensory resonance in a nearby subject, through image pulses that are so weak as to be subliminal. This is unfortunate since it opens a way for mischievous application

component. Before entering the TV set, a television signal can be modulated such as to cause pulsing of the image intensity by means of a variable delay line that is connected to a pulse generator.

Certain monitors can emit electromagnetic field pulses that excite a sensory resonance in a nearby subject, through image pulses that are so weak as to be subliminal. This is unfortunate since it opens a way for mischievous application of the invention, whereby people are exposed unknowingly to manipulation of their nervous systems for someone else's purposes. Such application would be unethical and is of course not advocated. It is mentioned here in order to alert the public to the possibility of covert abuse that may occur while being online, or while watching TV, a video, or a DVD.

DESCRIPTION OF THE DRAWINGS

FIG. 1 illustrates the electromagnetic field that emanates





T H A N O S

THE INFINITY GAUNTLET



THE SPACE Gem

Allows the user to exist in any or all locations, move any object anywhere throughout reality and warp or rearrange space. At full potential it grants Omnipresence.

KNOWN OWNERS:

Runner, Thanos Nebula
Adam Warlock, Pip the Troll,
Magus, Rune, Loki, Galactus,
Iron Man, Hood, Odeni,
Namor, Black Panther, Black
Widow



THE POWER Gem

Accesses all power and energy that ever has or will exist, and can boost the other gems' effects. Allows the user to duplicate almost any physical superhuman ability and grants nigh Omnipotence. It also grants the possessor the potential to manipulate all forms of energy for virtually any effect.

KNOWN OWNERS:

Champion of the Universe,
Thanos, Drax the Destroyer,
Thor, Magus, Rune, Lord
Pumpkin, Loki, Galactus,
She-Hulk, Titania, Mister
Fantastic, Red Hulk, Namor



THE SOUL Gem

Allows the user to steal, control, manipulate and alter souls, living or dead, and is the gateway to an idyllic pocket universe that is much like heaven. It also has the ability to steal the powers and abilities of others, which is why people argue that this gem is more powerful than the other gems. The Soul Gem is sentient and has a hunger for souls. It is often considered to be the most dangerous and corrupt of all the gems. Mastery of the gem would allow the user to control all life in the universe.

KNOWN OWNERS:

High Evolutionary, Adam
Warlock, Gardener, In-
Betweener, Thanos,
Nebula, Count Abyss,
Magus, Rune, Odeni,
Gemini, Loki, Galactus,
Syphonn, Dr. Strange



THE REALITY Gem

Allows the user to fulfill wishes, even if the wish is in direct contradiction with scientific laws. Occasionally stated to be the most powerful of the Gems if wielded without the other Gems to keep its reality-altering powers from accidentally surging out of control.

KNOWN OWNERS:

Stranger, Collector,
Thanos, Nebula, Adam
Warlock, Rune, Night-
Man, Loki, Galactus,
Black Bolt, Hood, Iron
Man, Black Widow



THE MIND Gem

Allows the user to greatly strengthen and enhance mental and psionic power and access the thoughts and dreams of other beings. Backed by the Power Gem, the Mind Gem can access all minds in existence simultaneously. When searching for it, the Grandmaster apparently discovered that the Mind Gem was the manifestation of the universal subconscious.

KNOWN OWNERS:

Grandmaster, Thanos,
Nebula, Adam Warlock,
Moondragon, Magus,
Rune, Primevil, Loki,
Galactus, Professor X,
Odeni, Hood, Ms. Marvel,
Beast, Black Widow



THE TIME Gem

Allows the user total control over the past, present and future. Grants its user visions of possible futures, the ability to see into the past as well as to stop, slow down or speed up the flow of time. Allows time travel i.e. the ability to change history and the future, can age and de-age beings and also be used as a weapon by trapping enemies or entire universes in unending loops of time. Also at full potential grants Omniscience.

KNOWN OWNERS:

Gardener, Thanos,
Nebula, Adam Warlock,
Odeni, Gamora, Maxam,
Magus, Rune, Hardcase,
Loki, Galactus, Namor,
Thor, Mister Fantastic,
Iron Man, Black Widow

in: [Vehicles](#), [Thor: Ragnarok Vehicles](#), [Avengers: Infinity War Vehicles](#)

Sanctuary II

EDIT

SHARE

For [Thanos](#)' cosmic hideout, see [Sanctuary](#).

The **Sanctuary II** is a massive warship commanded by [Thanos](#).^[1]

Contents [\[show\]](#)

History

Intercepting the Asgardians

The Sanctuary II tracked down the [Statesman](#) carrying the survivors of the [Ragnarök](#). On their way to [Earth](#), [Thor](#) and [Loki](#) witnessed the Sanctuary II intercepting them.^[2]

References

- ↑ 'Thor: Ragnarok': Marvel Boss Kevin Feige Explains That Mid-Credits Scene
- ↑ *Thor: Ragnarok* Mid-credits Scene

External Links

Sanctuary II



Owner	Thanos
Appearances	^
Movie	<i>Thor: Ragnarok</i> (mid-credits scene) <i>Avengers: Infinity War</i>
Status	Active

Recent Wiki Activity

[Escape from the Lighthouse](#)
AhsokaRules*6 • 2 minutes ago

[Valkyrie](#)
David Kaique • 18 minutes ago

[Avengers: Infinity War](#)
Avastral • 29 minutes ago

[Attack on Victor Stein](#)



MARVEL STUDIOS

BLACK PANTHER

2.16.18



Marvel Database

137,712 PAGES

ADD NEW PAGE

HUBS

CHARACTERS

COMICS

COMMUNITY

EXPLORE

DISCUSS

in: *Gods of Egypt members, Gods of Wakanda members, God Squad members, and 45 more*

Bast (Earth-616)

EDIT

SHARE

Contents [show]

History [Edit](#)

“ In Necropolis. The Wakandan City of the dead...where Black Panthers go to die. And where **you** will rule. As **king of the dead**. Every Panther that has ever lived, their strength, their knowledge is now yours. Every battle fought...every battle won. Unbeaten. Unbroken. A crown of the unconquered. A king of kings. My champion. My Black Panther. ”

-- Bast ^{src}

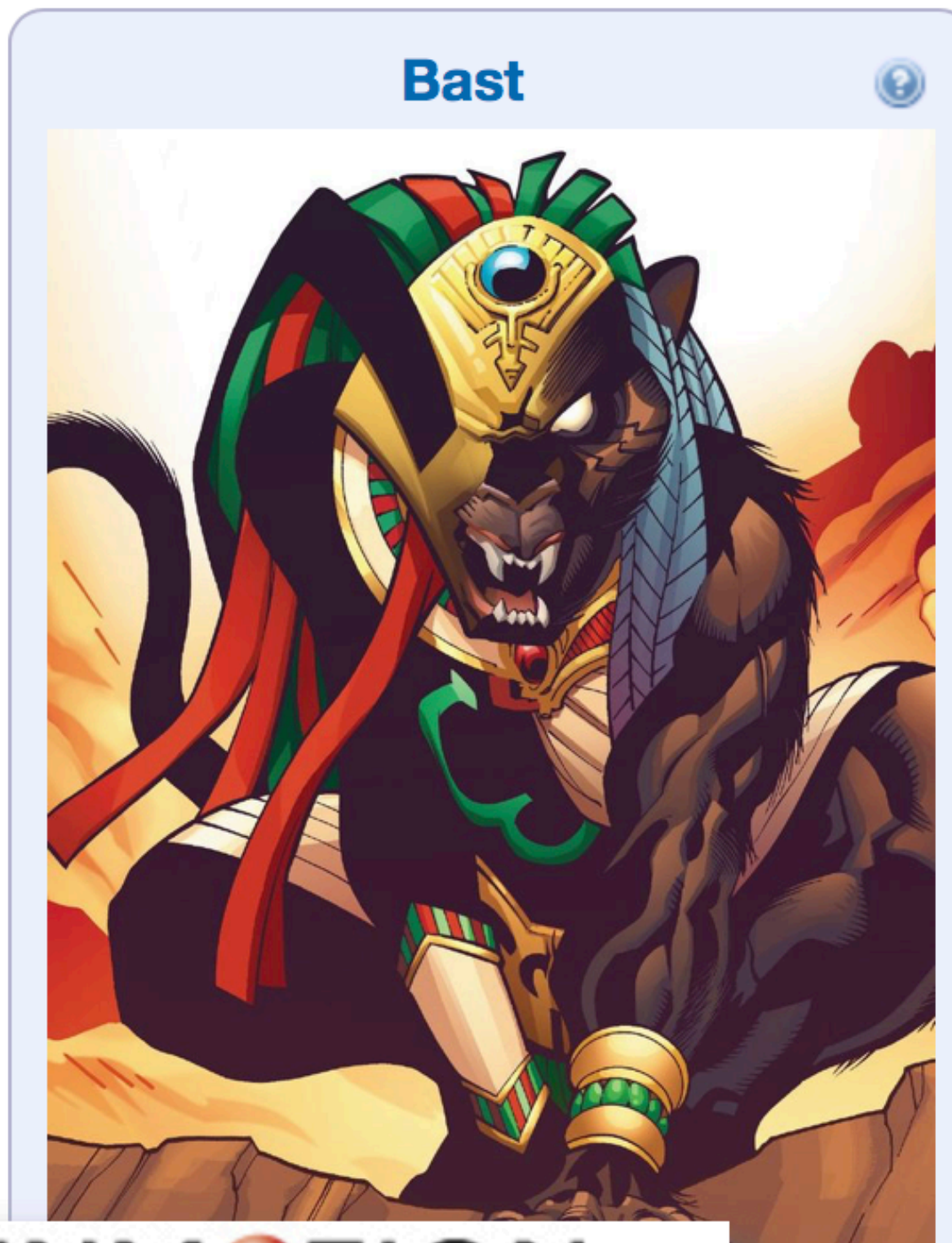

Bast^[1]

-Hathor,^[2]

electronics to go

INMOTION ENTERTAINMENT

Concourse D

Contents [\[show\]](#)

History  [Edit](#)

“ *In Necropolis. The Wakandan City of the dead...where Black Panthers go to die. And where **you** will **rule**. As **king** of the **dead**. Every Panther that has ever lived, their strength, their knowledge is now yours. Every battle fought...every battle won. Unbeaten. Unbroken. A crown of the unconquered. A king of kings. My champion. My Black Panther.* ”

-- Bast [src](#)

Bast

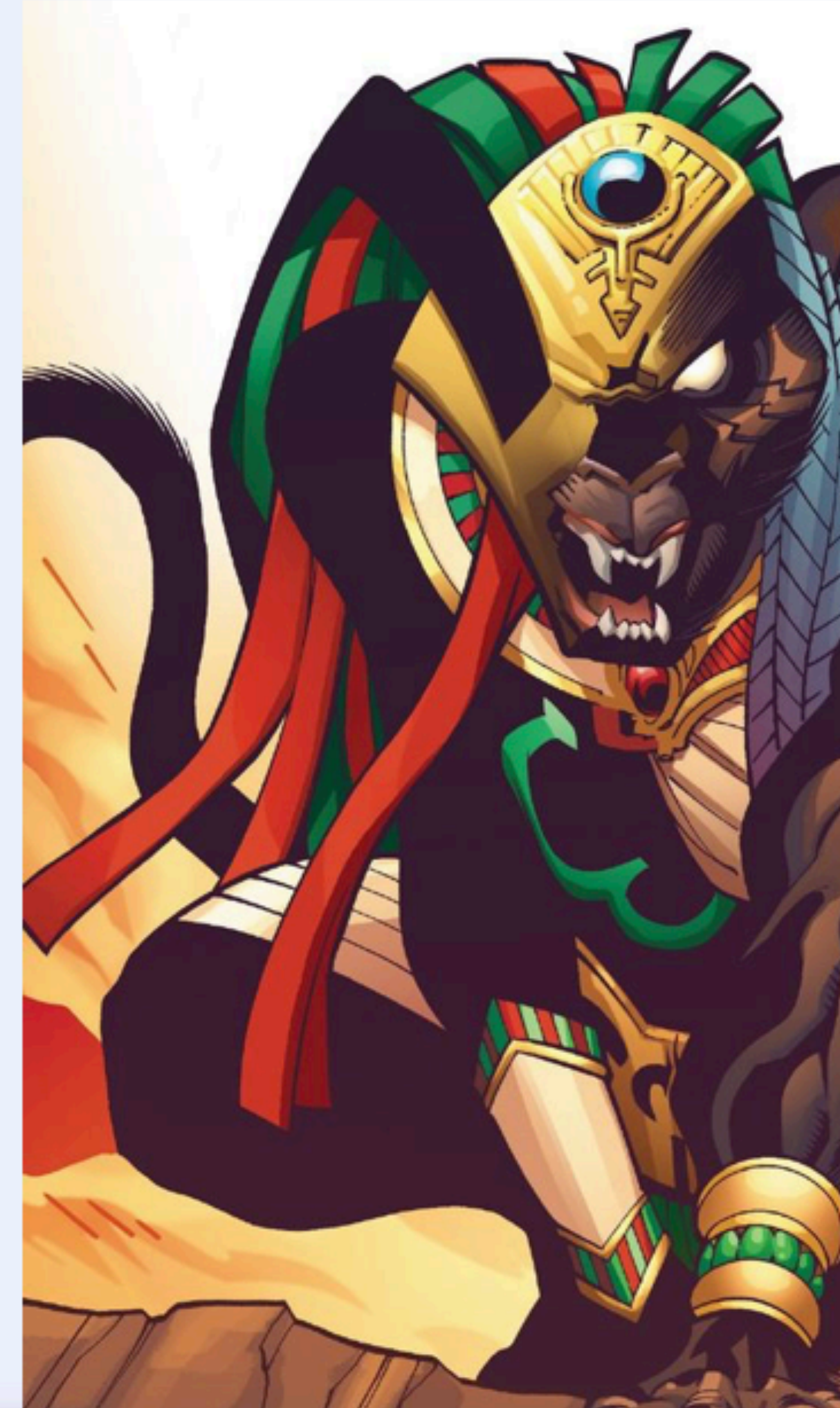

electronics
to 



INMOTION
ENTERTAINMENT

To the **law** and to the **testimony**: if it speaks not according to this word, **it is because there is no light in them.**

Isaiah 8:19-20





5 This then is the message which we have heard of him [Jesus], and declare unto you, that God is light, and in him is no darkness at all.

6 If we say that we have fellowship with him, and walk in darkness, we lie, and do not [have] the truth:

7 But if we walk in the light, as he is in the light, we have fellowship one with another, and the blood of Jesus Christ his Son cleanseth us from all sin.

1 John 1:5-7



Ephesians 5:8

Children
of the
LIGHT

**For at one time you were darkness, but now you are
light in the Lord. Walk as children of light.**



If we would at last share the reward of the righteous, we must wisely improve the time of our probation. Moments are more precious than gold.... – {*OUR HIGH CALLING 187.2*}

Time is Gold

Don't waste time anymore, precious the time we have

Life is short. The things of the world must perish with the using. Let us be wise, and build for eternity. We cannot afford to idle away our precious moments, or engage in busy activities that will bring forth no fruit for eternity. Let the time hitherto devoted to idleness, frivolity, worldliness, be spent in gaining a knowledge of the Scriptures, in



beautifying our life, and blessing and ennobling the life and character of others. This work will meet the approval of God, and win for us the heavenly benediction of
“Well done.”

– {***OUR HIGH CALLING 187.6***}



Satan's Strategy Is to Confuse the Senses — Satan's work is to lead men to ignore God, to so engross and absorb the mind that God will not be in their thoughts. The education they have received has been of a character to confuse the mind and eclipse the true light. Satan does not wish the people to have a knowledge of God; and if he can set in operation games and theatrical performances that will so confuse the senses of the young that human beings will perish in darkness while light shines all about them, he is well pleased.
— {Adventist Home 401.6}



Little Light
STUDIOS

www.littlelightstudios.tv

